



## UTM® RLS

### Integrated Cellular Monitor + Radar Level Sensor

The UTM® RLS is Anova's stand-alone telemetry solution for applications in locations that require tracking not only of the product, but also of where it is stored.



### FEATURES & BENEFITS



INTEGRATED WITH MAP APPLICATIONS FOR GEOGRAPHICAL INTERFACE AND MAPPING



STANDARD AND CUSTOMIZABLE REPORTS TO TRACK INVENTORY AND VISUALIZE TRENDS



EXCHANGE AND SHARE DATA WITH EXTERNAL SYSTEMS LIKE SAP



EXTENSIVE NOTIFICATION AND ALERT CAPABILITY TO PREVENT RUN-OUTS



EFFICIENT, LOW-POWER DESIGN FOR LONG BATTERY LIFE



24/7 TECHNICAL SUPPORT AND TRAINING



OVER-THE-AIR PROGRAMMABLE

### HOW IT WORKS



HIGH-RELIABILITY RADAR SENSOR REGULARLY CHECKS ASSET CONDITIONS



MEASUREMENTS AND ALERTS ARE COMMUNICATED TO SECURE CLOUD PLATFORM



VIEW READINGS, BUILD FORECASTS, AND CREATE REPORTS



SCHEDULE EFFICIENT DELIVERIES AND RESPOND QUICKLY TO CUSTOMER NEEDS

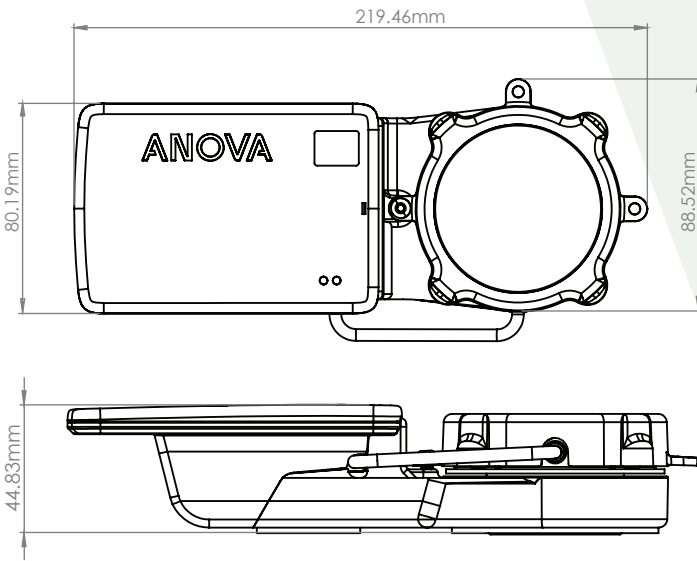

**DIMENSIONS:**

- 219.46mm (W) x 80.19mm (L) x 44.83mm (H)

**WEIGHT:**

- 0.1kg (0.22lb)

**MATERIAL:**

- Plastic, resistant to both UV and impact.

**TEMPERATURE RANGE:**

- -22°F to +140°F
- -30°C to +60°C

**INGRESS PROTECTION:**

- IP66/67/x8

**BATTERY LIFE:**

- Designed for 15 years.

**POWER INPUTS:**

- Primary lithium battery.

**RADIO:**

- GPS.
- Universal SIM supports cellular LTE CAT-M1 (North America), LTE CAT-M1 w/ 2G fallback (International).
- FCC, CE, UK CA

**REPORTING SCHEDULE:**

- Daily reporting with configurable alarms.

**NETWORKS:**

- **North America:** One monitor communicating on ALL MAJOR networks across the US and Canada.
- **International:** Multiple networks.

**RADAR:**

- Range: Up to 5ft (1.5m)
- Resolution: 1mm
- Accuracy: <0.4%

**Optimize supply chain logistics**

Improve planning and scheduling with enhanced visibility into your operations, including up-to-date location tracking of mobile assets.

**Enable predictive maintenance**

Avoid unexpected costs with actionable insight into the performance and health of multiple industrial assets. Improve safety and avert disruptions with customizable alerts and notifications.

**Improve asset performance**

Utilize customizable dashboards to benchmark tank and asset performance and unlock new efficiencies and value in your operations.

**DATA PORTAL & MOBILE APP**

EASY-TO-USE CLOUD SOFTWARE PLATFORM FOR MONITORING AND MANAGING INDUSTRIAL ASSETS AROUND THE WORLD

**ANOVA TRANSCEND™**

Monitor All Your Assets in One Place.

**BEAUTIFUL VISUALIZATIONS.**

**INSTANT INSIGHT.**

**DASHBOARDS, YOUR WAY.**

**POWERFUL ANALYTICS**

Create customized reports and custom charts.

**ULTIMATE SAFETY**

Ensure safety with custom alerts and notifications.

**EASY RTU MANAGEMENT**

Easily edit RTU settings and detailed asset info.

