







## UTM WITH RADAR LEVEL SENSOR (RLS) + TOP MOUNT ADAPTER

### INSTALLATION AND MOUNTING GUIDE

## 01 COMPONENTS

|  |  |  |
|--|--|--|
| <p><b>UTM</b></p>   | <p><b>Radar Level Sensor (RLS)</b><br/>PART #: SENS-4015-020-000</p>  | <p><b>2M ZAB Cable Extension (optional)</b><br/>PART #: SC62139401</p>  |
| <p><b>UTM Mount Bracket-3M-DL</b><br/>PART #: SC-850722_05</p>  | <p><b>Top Mount Adapter</b><br/>PART #: HAR-4096</p>                  |  |

## 02 INSTALLATION

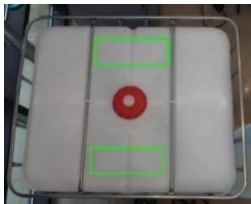

### STEP 1

The Radar Level Sensor (RLS) accuracy depends on the location at the top of the tank's surface where it is installed.

To ensure the optimal accuracy of the tank's level readings, it needs to be installed parallel to the liquid (less than 1.5 degrees of unevenness).

As such, for optimal performance, the ideal area where the RLS should be installed/placed is near the center of the tank where the surface is most levelled.



### STEP 2

After the surface's location is determined, clean that area thoroughly to ensure it is free from any greasiness/dirt and completely dry.

**IMPORTANT #1:** If the RLS is installed **incorrectly**, for example:

- **NOT PARALLEL TO THE FLUID/LIQUID** (an unevenness bigger than 1.5 degrees) – the Radar signal will reflect in a direction away from the radar receiving antenna causing low quality performance.
- **CLOSE TO THE EDGES OF THE TANK** – the RLS will struggle to measure the correct level reading due to the resultant radar reflections emitted by the tank's metal frame casing. The metal's radar reflections detected by the RLS will not be distinguished from the liquid's surface radar reflections resulting in an inaccurate measurement.
- **SURFACE IS GREASY/DIRTY AND WET** – The adhesives will fail to properly adhere to the surface and fail to secure that unit to the tank. The RLS position's unevenness will increase with time (inaccurate readings worsening with time) until it may become completely unattached from the tank (risk of unit falling and becoming physically damaged or lost).

### STEP 3

Mount the RLS on the top mount adapter.

Place a gasket on the RLS to secure the fitting between both parts. Attach the RLS on to the adapter by fitting the RLS 4 prongs into the 4 openings seen inside the adapter and twist/turn it to lock the fitting.

**WARNING: THIS STEP IS CRITICAL TO COMPLETE BEFORE PROCEEDING.**



**STEP 4**

To secure the RLS to the tank's top surface, peel the adhesive below the top mount adapter.

**STEP 5**

Place the RLS on the selected surface by pressing down firmly so the adhesive properly attaches to the tank's surface.

**WARNING:** For the adhesives to **SUCCESSFULLY ATTACH** to the surface, the **TANK SURFACE TEMPERATURE** must be **ABOVE 60°F/15°C** and a **CURING TIME** of **MINIMUM 24 HOURS** is needed.

**STEP 6**

**WARNING: It's critical the RLS sensor is already mounted in place before proceeding.**

**OPTIONAL STEP:** If the 2 meters extension cable is needed, firmly connect the RLS cable connector to the 2 meters extension cable's connector to ensure proper sealing. Secure the connection by breaking the cable's strap and placing it over the connectors.

After, connect the 2 meters extension cable connector to the UTM Port A only. The UTM® will begin to activate automatically.

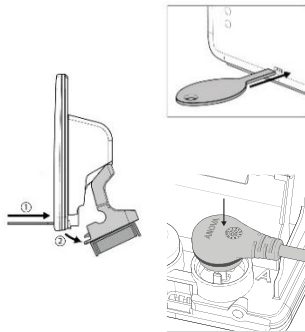
**STEP 7**

**WARNING: It's critical the RLS sensor is already mounted in place before proceeding.**

Connect the UTM to the RLS sensor:

- 1 - Detach bracket.
- 2 - If using only 1 sensor, install into PORT A on the rear of the UTM.
- 3 - Press down firmly on the ZAB plug until the O-Ring is sealed. It may require you to press down with 2 thumbs. The UTM® will begin to activate automatically.

**STEP 8**

The UTM Mount Bracket will have at the bottom a Velcro mount with an adhesive surface to secure/mount the UTM next to the tank.

Select the surface's location where the UTM device will be mounted and clean that area thoroughly to ensure it is free from any greasiness/dirt and completely dry.

**STEP 9**

Peel backing off from the Velcro adhesive and place the unit on the selected surface.

Fix the UTM in place by pressing down firmly so the adhesive properly attaches to the tank's surface.

**STEP 10 (OPTIONAL)**



If manual activation is required:

- 1 - Activate UTM by holding the activation wand in place for 6 seconds.
- 2 - LEDs will begin to flash.
- 3 - Watch for solid green to confirm successful communication.

**IMPORTANT #2:** If the activation attempt **failed** (solid red light at the end of the attempt), **wait at least 2 minutes** before trying to activate the UTM device again.

**TANK INFORMATION**

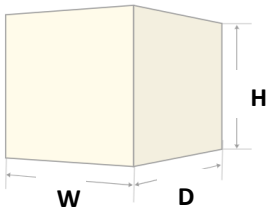
**IMPORTANT INFORMATION:** When contacting **Anova Support\***, please have the following information readily available to provide to us - **FOR EACH TANK:**

|  |   |
|--|---|
| UTM Device Serial Number (below QR code):  | UTM SN = _____ - _____ (9 digits)   |
| Tank Dimensions (in inches):   |   |
| <p><b>- Rectangular Shape:</b><br/>Height, Width and Depth</p>   | <p>Rectangular:<br/>H = _____ (inc)<br/>W = _____ (inc)<br/>D = _____ (inc)</p>  |
| <p><b>- Cylinder Shape:</b><br/>Length and Diameter</p>  | <p>Cylinder:<br/>L = _____ (inc)<br/>D = _____ (inc)</p>                         |
| Height (in inches) from the Tank's bottom until the RLS position:  | RLS Height = _____ (inc)  |
| Product in the tank:   |   |
| Current level of product (in inches):  |   |
| Photos of the RLS install/mounting on the Tank:  | Send photos by email with the Device SN on the email's subject.   |
| <p><b>*In the event of not being able to find the Device Serial Number on the Transcend Platform please inform Customer Support immediately.</b></p>   |   |
| <p>We welcome you to coordinate the time and place of your installs with Anova Support so we can better assist you and speed up your install time.</p> |   |















**ANOVA SUPPORT**  
**HOURS: MONDAY-FRIDAY 7AM TO 5PM (CENTRAL TIME)**

**LPG, F&L DIVISION:**  
+18444937762

support@anova.com

**IG DIVISION:**  
+18666268425

|   |   |   |
|---|---|---|
| <p><b>Anova Field Transcend</b></p>     | <p>AVAILABLE ON<br/>GET IT ON<br/></p>         |    |
| <p><b>Anova Field Transcend</b></p>     | <p>AVAILABLE ON<br/>Download on the<br/></p>   |    |
| <p><b>Anova Field Xfluid/Wesroc</b></p> | <p>AVAILABLE ON<br/>GET IT ON<br/></p>         |    |
| <p><b>Anova Field Xfluid/Wesroc</b></p> | <p>AVAILABLE ON<br/>Download on the<br/></p> |  |
| <p><b>Anova GO Unify</b></p>            | <p>AVAILABLE ON<br/>GET IT ON<br/></p>       |  |
| <p><b>Anova GO Unify</b></p>            | <p>AVAILABLE ON<br/>Download on the<br/></p> |  |